



All the excitement of the
GM small block available
in a marine engine

Vortec 5700 Marine Engine

Features & Benefits

- High-flow cylinder head with straighter intake ports and a higher compression ratio delivers impressive horsepower
- Valvetrain features advanced design silent timing chain for added durability and positive inlet valve stem seals for reduced oil consumption
- Roller valve lifters for reduced friction and improved performance
- Composite front timing cover for noise reduction and corrosion protection
- Flywheels are offered with front- or rear-mounted ring gears for various starter locations to suit inboard and stern drive applications
- Water pump is effective rotating in either a clockwise or counterclockwise direction
- Cylinder head gaskets have stainless steel core for corrosion resistance
- Offered with mechanical or electronic throttle body unit
- Fuel injection reliability improved by using new injector design



The small block V8 family of marine engines offers proven reliability and durability over a range of horsepower and torque. (8MH model shown.)



MEFI-5 (Marine Electronic Fuel Injection - Fifth-Generation), is an advanced engine controller capable of meeting all the emissions, OBD-M and driveability requirements of marine applications.

Available Options

- An electronic control module (ECM) and related hardware are available in kit form. The ECM uses state-of-the-art technology to optimize fuel and spark requirements.
- EST and HEI distributors and coils are available in kit form.

Vortec 5700 Feature Focus

GM Powertrain takes its expertise in designing outstanding Vortec truck and SUV engines and leverages it to make sophisticated yet extremely durable marine engines. In addition, the well-recognized Vortec brand name by itself has become a valuable selling tool for OEMs.

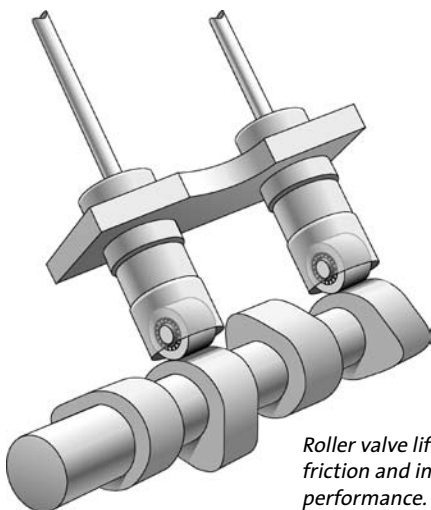

Roller valve lifters reduce friction and improve performance.

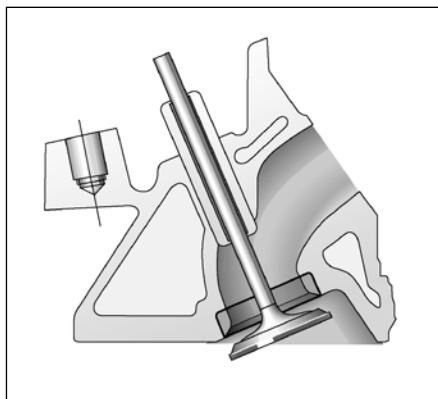

The exhaust valve seat inserts in the cylinder head provide superb durability.



Many of GM marine engines are Vortec engines. Vortec means uncompromised power — outstanding power with no sacrifice in fuel efficiency or durability and very little required maintenance.

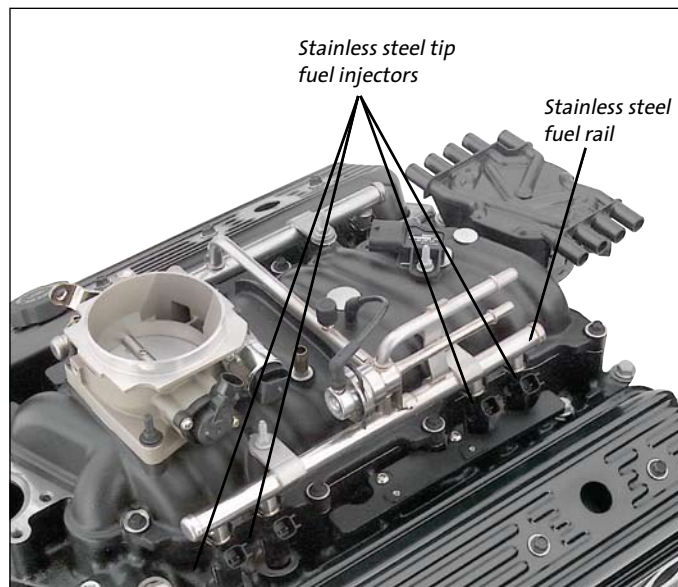

The Integral Air Fuel Module (IAFM) incorporates several features into one integral assembly. The bottom of the inlet manifold is made of iron and the top is made of aluminum. Integrated into the module are a stainless steel fuel rail, stainless steel tip fuel injectors, and a throttle body that includes a Throttle Position Sensor (TPS) and an Idle Air Control (IAC) motor.

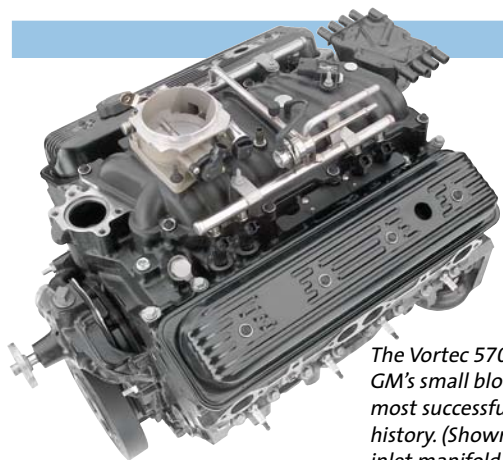

The Vortec 5700 V8 engine is part of GM's small block V8 series, one of the most successful engines in automotive history. (Shown with optional IAFM inlet manifold.)

Specifications

Type: 5.7L V8 Gen 1e Small Block
Displacement: 350 cid (5736 cc)
Engine Orientation: Longitudinal
Compression Ratio: 9.4:1
Valve Configuration: Overhead Valves
 (2 valves per cylinder)

Assembly Site: Toluca, Mexico
Valve Lifters: Hydraulic Roller
Firing Order: 1-8-4-3-6-5-7-2
Bore x Stroke: 101.60 x 88.39 mm
Bore Center: 111.76 mm
Bore Area: 648.59 cm²
Fuel System: Port Fuel Injection with
 mechanical or electronic throttle body unit
Fuel Type: Regular Unleaded
Horsepower: 292 hp (218 kW) @ 4800 rpm
Torque: 370 lb-ft (502 Nm) @ 3200 rpm

Actual power levels may vary depending on OEM calibration and application.

Fuel Shutoff: MEFI-5 Yes
Shipping Weight: 432 lb (196 kg)
Emissions Controls: Positive Crankcase
 Ventilation

Materials:

Block: Cast Iron GM232-M
Cylinder Head: Cast Iron
Intake Manifold: Iron Lower,
 Aluminum Upper
Exhaust Manifold: None
Main Bearing Caps: Cast Iron GM232-M
Crankshaft: Nodular Iron
Camshaft: 5150 Steel Billet
Connecting Rods: Forged - SAE 1141

Information may vary with application. All specifications listed are based on the latest product information available at the time of publication. The right is reserved to make changes at any time without notice.

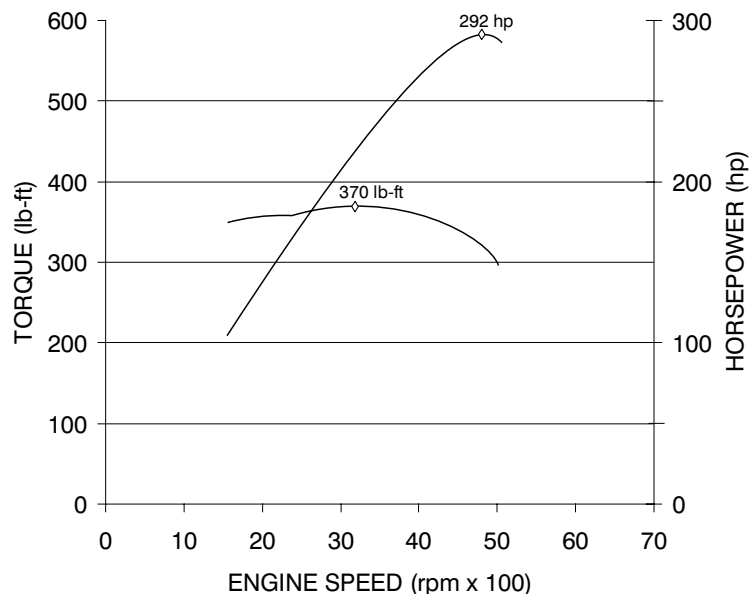

Actual power levels may vary depending on OEM calibration and application.

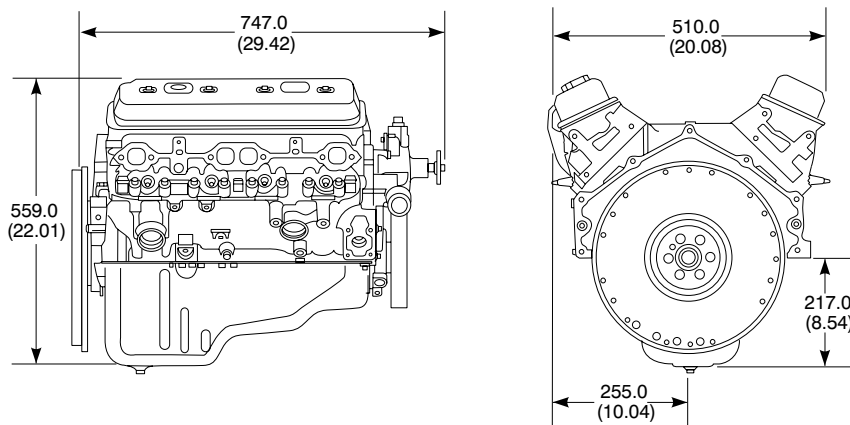

GM Powertrain

www.gmpowertrain.com